



AquaScan Manual, Rev. 1.6
KE/CSW-series

AquaScan User's Guide: 4.00 Model: KE-series
AquaScan General Directions, version: 1.6 Model: CSW-series

© Copyright AquaScan ® 2010

CONTENTS:

PAGE:

Introduction:..... 3

AquaScan User’s Guide4

 Starting the count:5

 Counting pause:5

 More data display.....6

 Error messages:7

 Get more information about the counting process:8

 Top level menu:8

 Clock menu8

 Parameters menu8

 Results menu10

 Results menu, menu page 110

 1:Res>PC10

 2:Res>DISP10

 Results menu, menu page 212

AquaScan General directions.....13

 Electrical connection/disconnection13

 Connection of transportation-pipe to Reg. Unit:.....13

 Maintenance/Checklist:.....15

 AquaScan counting principle and capacity:.....15

 Calibration:15

 Memory:.....16

 Previous average:16

 Details about the rub window alarm:16

 Changing parameters:17

 Changing language:17

 Standard parameter settings:18

Introduction:

Thank you for choosing AquaScan Fishcounters. We are certain that you will be satisfied with our product. If you have any comments or suggestions, be sure to share them with us.

This manual consists of two main sections:

AquaScan User's Guide

For the everyday use and operation of your AquaScan system.

AquaScan General Directions

Contains vital information on the arrangement, connection and counting principle of the AquaScan system. It is *very important* that operators read General Directions before installing and operating the AquaScan.

Contact information:

Mailing address:	AquaScan AS Gosenstien 1 N-4140 Hafrsfjord Norway
Service/visiting address:	AquaScan AS Nordlysveien 4 N-4340 Bryne Norway
Telephone:	+47 51 48 33 95
Telefax:	+47 51 48 33 91
E-mail:	aquascan@aquascan.com
Website:	www.aquascan.com

AquaScan User's Guide

version: 4.00 Model: KE-series



The Registration Unit(s) is first connected to the Control Unit. The system is then turned on by pressing the **On/Off** button.

AquaScan Fishcounters

Note! It is important that the connections are carried out in this order.

After approx. 10 sec. the Control Unit will show which Registration Units it has contact with, and how much of program transfer that has been finished:

C1234: WAIT...
0%

This example shows that all channels are connected.

The program transfer normally takes ca. 30sec. The message **NO COUNTERS** will be shown if the Control Unit does not encounter any Registration Unit.

The following will be showed when the program transfer is finished:
The following will be showed when the program transfer is finished:

WEIGHT(g) Cx:

x may be 1,2,3 or 4. C1, C2, C3 and C4 are related to the inputs at the Control Unit.

WEIGHT(g) Cx:

For each channel type the average weight in gram for the fish to be counted in The given channel and press **Enter** (Enter/Yes). When the average weight is given by the operator the channel will be calibrated at the start of the count.

Alternatively, if you wish to use the previous size for a channel (NOTE: same cage or tank) you don't need to give the average weight. This may also be used if a power loss has occurred. To resume counting press **Enter** only and the display will show: **Start Cx:(number) Y/N**

Press **Y** (Enter/Yes) and start will be from last number.
Press **N** (Delete/No) and start will be from 0.

Starting the count:

When the questions for all channels are answered the display will show:

ALARM Y/N

Press **N** and the counter starts counting, see next section.

Press **Y** if you wish the system to give an alarm (siren) when a given number of fish have passed. The display will show:

AlarmNbr Cx:

Enter the number of fish for the displayed channel and press **Enter**. The counter is asking for the alarm number for each channel. Press **Enter** only if no alarm is intended for the given channel. After all channels are entered the counter will start counting.

The counter displays the sum of fishes passed through the shown channels. The message **CAL** is shown after the number whenever calibration is performed for one or more channels shown.

An example, if the display reads:

C13: 162 Cal

it means that 162 groups of fish have passed C1 and C3 together. Here are one or both channels in calibration mode. A press on indicator C3 will hide channel 3 and the result in channel 1 is viewed e.g.:

C1: 70 Cal

This means that calibration is at least in progress for channel 1.

If the same indicator (C3) is pressed again, the display will return to show the sum of units C1 and C3:

C13: 162 Cal

Now a press on indicator C1 (hide C1) may give this result:

C3: 92

Please note that the text **Cal** does not follow the number viewed here. This means that there is no calibration on channel 3. This example shows that the average size on this channel is based on the former counting operation. No average weight was given for this particular channel.

When the calibration is finished (at least 125 fish) the text Cal will automatically disappear and AquaScan will show the correct number of fish passed during the calibration.

Pressing the belonging channel-button will stop an alarm (Alarm number, Error message)

Counting pause:

You can temporary stop (pause) the counting with the stop button (**0/Stop** key). The screen will show:

CONTINUE Y/N

Press **Y** to continue counting or

Press **N** to restart the system and the screen will read:

WEIGHT(g) Cx:

Type in a new average weight or press only **Enter** to resume counting.

More data display

While counting the operator may view more data at the same time by pressing > (6/>)..
In order to go back to normal view press < (5/<).

In order to select from possible data combinations use ^ (7/^) or v (v/8).

Three or four data will be displayed at the same time.
What data is depending on how many connected Registration Units.
If only one Registration Unit is connected the first view can be:

Cx:2 Cx:20g	Number for Cx	Average weight for Cx
Cx:0kg Cx:2.0m/s	Total weight for Cx	Average speed for Cx

Next view by pressing ^ (7/^):

Cx:20g Cx:0kg	Average weight for Cx	Total weight for Cx
Cx:2.0m/s Cx:100%Ne	Average speed for Cx	Ne in % for Cx

Next view by pressing ^ (7/^):

Cx:0kg Cx:2.0m/s	Total weight for Cx	Average speed for Cx
Cx:100%Ne Cx:0%Nst	Ne in % for Cx	Nst in % for Cx

Next view by pressing ^ (7/^):

Cx:2.0m/s Cx:100%Ne	Average speed for Cx	Ne in % for Cx
Cx:0%Nst Cx:2	Nst in % for Cx	Number for Cx

If two Registration Units are connected data for both can be displayed at the same time:

Cx:2 Cx:20%#	Number for Cx	Number for Cx in % related to total
Cy:8 Cy:80%#	Number for Cy	Number for Cy in % related to total

If three Registration Units are connected data for all can be displayed at the same time:

Cx:2 Cy:8	Number for Cx	Number for Cy
Cz:4	Number for Cz	

If four Registration Units are connected data for all can be displayed at the same time::

C1:2 C2:8	Number for C1	Number for C2
C3:4 C4:6	Number for C3	Number for C4

If more than one Registration Unit is connected the displayed channels will be the same as shown in normal view.

If the operator presses C1-C4 normal view will be shown, and the response will be as normal.

Error messages:

RUB WINDOW C_x

x may be **1,2,3** or **4**. The counting is stopped for this channel. Clean all surfaces between the light- source and sensor in the referred Registration Unit. Then press the corresponding C_x key.

SUNLIGHT C_x

x may be **1,2,3** or **4**. This is a warning, the counting is not stopped. Make sure that the view of the lenses are not exposed to sunlight. Then press the corresponding C_x key.

CAL FAIL C_x

x may be **1,2,3** or **4**. The Calibration was not correctly performed. A press on the belonging channel button will view the number calculated. Stop counting (N/S key). Restart and do a new calibration for this channel.

C_x: yyy Cerr

x may be **1,2,3** or **4**, yyy is number. The calibration was not performed correct, but the error was accepted. Press **Stop** (0/Stop) and make a new calibration for this channel.

POWER LOST!

Power disappeared during previous counting (not stopped with the 0/Stop key). Press **Enter** to restart. When screen shows WEIGHT(g) C_x, press **Enter** to resume counting.

NO SPEED C_x

x may be **1,2,3** or **4**. This is a warning, counting is not stopped. The speed calculations in the Registration Unit are having a problem. This may be caused by too much water in a dry-counter, too much air in a fullwater- counter, or dirt on the transparent pipe.

LENS PROBLEM C_x

x may be **1,2,3** or **4**. This is a warning, counting is not stopped. The lens at the *out*-side is seeing dirt.

REG.KOM ERR C_x

x may be **1,2,3** or **4**. This is a warning, counting is not stopped. The Control Unit receives incorrect data from the Registration Unit. This may be caused by a faulty Unit (Registration Unit, Control Unit or cable), or disturbance from external equipment.

LOST C_x

x may be **1,2,3** or **4**. The Control Unit does no longer receive data from the Registration Unit.

C_x: yyy LOST

x may be **1,2,3** or **4**, yyy is number. The Control Unit does no longer receive data from the Registration Unit, and the error was accepted.

MISSING CHANNEL!

A fullwater-counter consists of two channels, and one channel is missing. Check connections.

OVERRUN C_x

x may be **1,2,3** or **4**. The counting is stopped for C_x. The counting data could not be processed fast enough and data has been lost.

Get more information about the counting process:

It is possible to get more information about the counting. The counter will remember the 15 latest counting operations. The Registration Unit(s) does not need to be connected in order to access the information.

The display shows:

WEIGHT(g) Cx: where x is 1 or the channel number of the first connected Registration Unit.

At this point special commands may be given. When the **Delete** key is pressed at the start of the Weight a ? is displayed. The next character will overwrite the ?. If **Delete** is pressed again, the ? will disappear.

WEIGHT(g) Cx:

Menu is pressed in order to start the menu system.

Top level menu:

1:Clock 3:Results
2:Params

1 selects the Clock menu, **2** selects Parameters menu, **3** selects Results menu, **Stop** leaves the menu system.

Clock menu

Clock menu, date submenu:

Date:05-15-2006 New?

Yes selects date adjustment.

No or **Stop** continues to time of day submenu.

If **Yes** is selected the month is first set by two digits and **Enter**, then day in month, and finally year is set with four digits. When date is set the operator should select **No** or **Stop** to enter the time of day submenu.

Clock menu, time of day submenu:

Time: 09:44:13 New?

Yes selects time of day adjustment.

No or **Stop** goes back to top level menu.

If **Yes** is selected the hour is first set by two digits and **Enter**, then minutes, and finally seconds is set by two digits. When the time is correct the operator should select **No** or **Stop** in order to go back to top level menu.

Parameters menu:

1:New WGF 2:New CTF
C1: 1000 1000

1 selects new weight factor (WGF) for displayed channel

2 selects new count factor (CTF) for displayed channel

> and **<** displays next and previous channel. **Stop** goes back to top level menu.

The Weight factor is used to adjust the displayed weight.

The Weight factor will be limited to values from 500 to 2000 (-50 %, +100 %), and may be adjusted for each channel.

A value of 1000 means no weight adjustment.

If the Weight factor for C1 is set to 500 the displayed weight for C1 will be one half of the value compared to if the weight factor was 1000. In the same manner, if the weight factor for C2 is set to 2000 the displayed weight for C2 will be twice the value displayed if the weight factor was 1000. Calculated weight factors should be rounded to closest integer.

An example:

C1 displays 1778gram, while correct weight is 2,12kg

C2 displays 2033gram, while correct weight is 1,49kg

If weight factor for both channels was set to 1000, the equation for the new weight factor is:

Weight factor = (Correct weight in gram) * 1000 / (displayed weight in gram)

For C1: Weight factor = 2120 * 1000 / 1778 = 1192

For C2: Weight factor = 1490 * 1000 / 2033 = 733

If previous weight factor for C1 was set to 1100 and for C2 to 1050 the equation is:

New Weight factor =

(Correct weight in gram) * 1000 / ((displayed weight in gram) * 1000 / (Old Weight factor))

which equals:

New Weight factor = (Correct weight in gram) * (Old Weight factor) / (displayed weight in gram)

For C1: New Weight factor = 2120 * 1100 / 1778 = 1312

For C2: New Weight factor = 1490 * 1050 / 2033 = 770

The Count factor is used to adjust the displayed count.

The Count factor will be limited to values from 950 to 1050 (+/- 5 %), and may be adjusted for each channel.

A value of 1000 means no count adjustment.

If the Count factor for C1 is set to 950 the displayed count for C1 will be 95 % of the value compared to if the weight factor was 1000. In the same manner, if the Count factor for C2 is set to the displayed count for C2 will be 5 % greater than the value displayed if the Count factor was 1000.

Calculated weight factors should be rounded to closest integer.

An example:

C1 shows 10560 fishes, while correct number is 11000 fishes.

C2 shows 20333 fishes, while correct number is 19755 fishes.

If Count factor for both channels was set to 1000, the equation for the new weight factor is:

Count factor = (Correct number) * 1000 / (displayed number)

For C1: Count factor = 11000 * 1000 / 10560 = 1042

For C2: Count factor = 19755 * 1000 / 20333 = 972

If previous Count factor for C1 was set to 970 and for C2 to 1050 the equation is:

New Count factor =

(Correct number) * 1000 / ((displayed number) * 1000 / (Old Count factor))

which equals:

New Count factor = (Correct number) * (Old Count factor) / (displayed number)

For C1: New Count factor = 11000 * 970 / 10560 = 1010

For C2: New Count factor = 19755 * 1050 / 20333 = 1020

Note: If AquaScan Win is used with PC-Control, the Weight factors and Count factors from AquaScan Win will override the previous set factors in the Control Unit.

Results menu

Results menu, menu page 1:

```
1:Res>PC  2:Res>DISP  
05-10-06 09:49:01
```

1 selects menu for transfer of counting result to PC.
2 selects menu for display of counting result at Control Unit.
< selects previous count result, > selects next count result.
The second display line shows the start time for the selected counting result.
Stop goes back to top level menu.
v and **^** selects next or previous menu page in Results menu,

1:Res>PC

Transfer counting result to PC:

```
Send counting Y/N  
05-10-06 09:49:01
```

Yes starts data transfer,
No or **Stop** goes back to Results menu.

In order to be able to Transfer previous counting's to PC the Control Unit must be connected to a PC running AquaScan Win version 2.2 or later.

2:Res>DISP

Display counting result, Number screen:

```
Numb:191 100%  
C1 05-10-06 09:49:01
```

> or < displays next or previous channel, if more channels was in use. **v** or **^** displays next or previous screen.
Stop goes back to Results menu.

Number of fishes for selected channel.

% tells the percentage of the total number of fishes for all channels.

Display counting result, Start Number screen:

```
Start Numb:0  
C1 05-10-06 09:49:01
```

Number of fish the counting was started for displayed channel.

Display counting result, Calibration number screen:

```
Calib Numb:54  
C1 05-10-06 09:49:01
```

Number of fishes during calibration for displayed channel.

Display counting result, Calibration single fishes screen:

```
Calib Ne:89%  
C1 05-10-06 09:49:01
```

Number of single fishes during calibration in % of number of fishes during calibration for displayed channel.

Display counting result, Start Weight screen:

```
Start Weight:20g  
C1 05-10-06 09:49:01
```

Given weight for displayed channel.

Display counting result, Calibration Weight screen:

Calib. Weight:25g
C1 05-10-06 09:49:01

AquaScan weight estimate (average in grams) after calibration for displayed channel.

Display counting result, Average weight screen:

Avg. Weight:24g
C1 05-10-06 09:49:01

AquaScan weight estimate (average in grams) after counting for displayed channel.
(This weight estimate is not yet optimized for smolt and different fish species)

Display counting result, Total weight screen:

Total:4kg 100%
C1 05-10-06 09:49:01

Total weight in kilograms after counting for displayed channel.
% tells the percentage of the total weight for all channels.

Display counting result, Speed screen:

Speed:2.19m/s
C1 05-10-06 09:49:01

The average speed in m/s for displayed channel. As a rule the speed should be greater than 2 m/s.
Max. 3 m/s for fish less than 200g. Recommended speed is at least 3m/s for bigger fish.

Display counting result, Ne/Nst screen:

Ne:86% Nst: 2%
C1 05-10-06 09:49:01

Ne: "Number single fishes" in % of number of fish counted for displayed channel.
This value tells how hard the system is loaded.
As a rule Ne should be at least 30 % or more. When a single fish is detected (the system looks for single fishes during the whole count operation) this is used in the average calculation.

Nst: "Noise" or number of rejected areas in % of number of fishes for displayed channel.
If an area is measured to be less than 70 % of the average area,
This area is rejected. Normally Nst will be less than 1 %.

Display counting result, Status screen:

```
Status:OK  
C1 05-10-06 09:49:01
```

Status for displayed channel can be one of:

- OK - Calibration was not performed when the counting was stopped.
- Cal - Calibration was performed when the counting was stopped.
- Cerr - Calibration failed.

Display counting result, Stop time screen:

```
Stoptime:09:55:58  
05-10-06 09:49:01
```

Time when counting was stopped.

Display counting result, Run time screen:

```
Runtime:00:03:45  
05-10-06 09:49:01
```

How long the counting did take.

Display counting result, Effectiveness screen:

```
Eff:73kg/h  
C1 05-10-06 09:49:01
```

Number of kg/hour for displayed channel.

Results menu, menu page 2:

```
1:Copy Res&Param>Cur  
05-10-06 09:49:01
```

1 selects copying results and configuration from selected Result into new result. This can be used for next counting.
< selects previous count result, > select next count result.
v and ^ selects next or previous menu page in Results menu,
Stop goes back to top level menu.

AquaScan General directions

version: 1.6 Model: CSW-series

Electrical connection/disconnection

Avoid water at the contact pins of the connectors whenever the Registration Units are connected to the Control Unit, and when powering the system. Connect the Registration Units to the Control Unit before you apply the correct grounded power source. If the power is coming from a generator etc. it is important that AquaScan is not connected to power during start-up or shut-down of such equipment. Ensure that the power source is stable.

The Control Unit will do a self-test during power-up.

Make sure that the connectors are tightened properly. If you are using an extension cord between the Registration Unit and the Control Unit, make sure that the connectors are never put directly under water. The power source must be turned off before disconnecting the Registration Units. Always mount the sealing cap on both the male and female connectors when not in use, to avoid access of dirt and water.

Connection of transportation-pipe to Reg. Unit:

The Registration Unit should be installed in such a way that the long sides are vertically. At inlet (marked IN) connect a straight pipe with a length of minimum 1 meter and same diameter as the Registration Unit. This pipe can then e.g. be connected to another pipe with another diameter. The reason for the angle between the de-waterier and the straight pipe is to spread and accelerate the fish, before the fish passes through the counter.

The pipes need to be completely opaque to avoid direct sunlight reaching into the unit. The area of registration (light sheet and lens) in the Registration Unit must be protected against light from the outside world.

Try to minimize the amount of water flowing through the unit. Too much water can disturb the sensor's measurement. A dewatering system will be necessary especially if the level of water can reach over 1/4 of the pipe. Avoid water to foam/whirl through the counter. Make sure the counter does not «count» water and do not add water until the whole fish has passed through.

Arrangement:

The Registration Unit must be installed in a 90° vertical position.

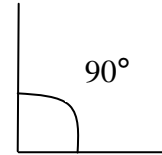
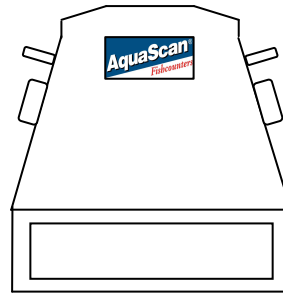

The whole assembly (Registration Unit and pipes) should be tilted forward to a suitable angle (approx. 30 degrees) to assure steady flow (approx. 2,5-3 meter/second) through the counter. (The Control Unit can view the average speed of the fish in the Result Menu when the counting is stopped).

Example of system arrangement:

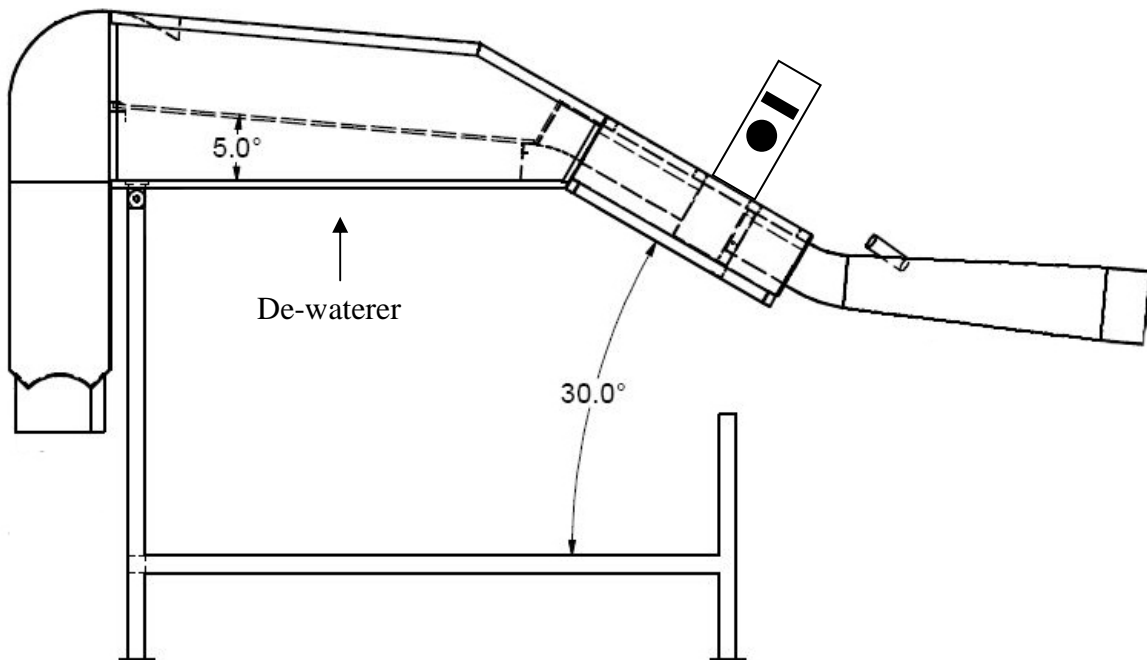

Maintenance/Checklist:

To achieve the best counting result, be content with the maintenance of the counter. The units should always be cleaned after use. Follow also this checklist before every use of the counter:

Use a moist cloth to clean the transparent pipe in the counter. Open the inspection-hatch and check that everything is clean: window in front of lenses, transparent pipe and the light source. (The lenses look through the top of the pipe towards the light source at the bottom of the pipe). Remove any droplets on the window and clean it with DPI-MICROCLEAN. (We want to achieve the antidroplet effect – opposite effect to car polish/wax).

During counting, drops of water may form at the window in front of the lenses or on the splash-cover. Drops of water on the window/splash-cover can lead to inaccurate count typically if the fish are small. To avoid this problem, clean the window with DPI-MICROCLEAN (the counter must be stopped). Keep the splash-cover open if the fish is smaller than 200g. During the counting operation, check that there is no droplets on the window.

AquaScan counting principle and capacity:

It is of no matter whether one or several fish pass the sensor simultaneously. AquaScan measures the size (shape) of all objects passing through the unit. Capacity is only limited that the fish must not lie on top of each other and then cover the view of the sensor (lens). The number calculated is the total size of all fishes divided on the last calculated average size. The average size is continuously calculated and updated during the whole counting process. (AquaScan will calculate the average size when a “single fish” is registered). You may recognize that sometimes AquaScan does not count when a fish pass through or count two instead of one etc. In the first case the fish may be too small to initiate a count or the average has been changed. However, the size is memorized and this will have an effect on the total count.

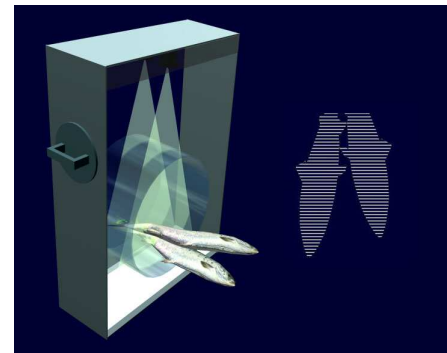

Calibration:

When the operator types in the average weight, at least the first 125 fish passing through this Registration Unit will be used to calibrate the system for this channel. The text **Cal** will follow the number of group of fish (one or several fish) in channels where calibration is in progress. During this mode the system will not separate between one or several fish passing through at the same time.

During calibration, at least 50 of the first 125 group of fish in the channel need to be a single fish (distance between every fish). AquaScan will show the correct number of fish passed during the calibration as soon as the calibration is finished. When at least 125 fish have been recorded, the system will automatically change calibration mode to normal counting.

Ideally, if all measurements are OK you should see **124 Cal, 125 Cal** (one channel viewed) and then the correct number e.g. **145** without the text **Cal**. If some of the measurements during calibration are bad (you will see **126 Cal, 127 Cal, ...**) some of the fish will not be used to calibrate the system. Bad measurements may be caused by e.g. too slow speed of the fish or too much water.

Memory:

Although the power is removed, the counter will memorize the last calculated number and average size for each channel. This is saved until you perform a new counting operation on the particular channel.

(Example: The power accidentally disappears when you are performing a counting operation. When the power is applied again you can continue the counting process from where it left; just press the **Enter** key when the screen reads **WEIGHT(g) Cx:** (x may be **1,2,3** or **4**)).

The counter will remember the 15 latest counting operations, see User's Guide.

Previous average:

If the display reads **WEIGHT(g) Cx:** (x may be **1,2,3** or **4**) and you only push the **Enter** key, counting based on the previous average size can be done. This option must only be used when fish in both the first and the second group are of the same size (cage/tank). If you use the previous average size you will get the message **StartCx:** (number) **Y/N**. You are now able to start or continue the counting process from the number of fish calculated during the previous counting operation.

Details about the rub window alarm:

If the screen reads **RUB WINDOW C2**, no counting will be performed on channel 2 and you will lose the number of fish passed when this message appeared on the screen. The counting will be normal in the other channels (if there is no other **RUB WINDOW** messages). It is not necessary to stop the counter. If you press the **C2** button the system will check the channel and if it is OK start to count from the last number calculated just before the **RUB WINDOW** message appeared.

Note: AquaScan performs special filtration algorithms to "take care of" small particles, water etc. If you get a **RUB WINDOW** message, be quick to push the corresponding key for the channel. AquaScan will check the channel and continue counting unless something is still blocking the view of the lenses.

General: During the counting, open the inspection-hatch regularly to check that the pipe/light source is clean and look for droplets on the window in front of the lenses (the lenses may be disturbed even if there have been no **RUB WINDOW** message). Also assure that the fish has a steady flow through the unit.

Changing parameters:

The Control Unit uses several software parameters to control the counting. Depending on your specific installation an operation of the system, some of these parameters may need to be adjusted by the operator.

When the Control Unit asks for Weight for the first connected Registration Unit, it will accept special commands. All commands are initiated with **Delete** key. Whenever **Delete** is pressed as the first command a ? is shown. The next character will overwrite the ?. If **Delete** is pressed again the ? will disappear.

To change parameters in setting #1, use the following code:

Delete < > 3 Enter

This code contains parameters which will set up how the Control Unit responds to other equipment.

To change parameters in setting #2, use the following code:

Delete < > 4 Enter

This code contains no parameters which will set up how the Control Unit responds to other equipment.

The arrow buttons may be used to navigate between parameters in each code set.

To move to the next parameter in a code set, press > (6/> key) or **N**.

To move to the previous parameter in a code set, press < (5/< key).

To move to the first parameter in a code set, press ^ (7/^ key).

To move to the last parameter in a code set, press v (8/v key).

To leave a code set, press **Stop**, or at the last parameter in a set press **N** or edit it.

To edit a parameter, press **Y**, and then give the new value, followed by **Enter**. If **Enter** is pressed without any value, the original value is kept.

Changing language:

WEIGHT(g) Cx: In order to change language (English or Norwegian), or to look at program versions and serial number, use this code: **Delete < > 0 Enter**

If the language is set to Norwegian the display will show:

LNG=0 Ny? Answer **Y**, and set LNG= **1**. Press **Enter**. The program versions are now displayed, and another press at **Enter** will show the serial number for the Control Unit. Press **Enter** once more in order to proceed to WEIGHT.

Standard parameter settings:

Parameter setting #1: (Delete < > 3)

AUT	1	
BSS	8	
SUP	1	
EPI	4	
PIX	5	
LIN	64	
LOG	0	(PC-connection: LOG=110)
REF	50	
ALD	0	
VEL	30	
DLL	50	
DLH	50	
IRM	0	
CON	0	
WGT		Constantly changing
WLL	20	
WLH	20	

Parameter setting #2: (Delete < > 4)

NMS	125	
NOL	70	
MAT	512	
AMI	1920	
DSP	100	
STP	2	
SUN	40	
ALI	70	
TDH	5	
TDR	0	
FEF		Does not matter on CSW-series
LEN	128	
SPC	64	
CFN	50	
SLL	100	
SLH	170	
EDP	0	

